

9.0 End of Line Monitoring

An End of Line monitoring Diode or an End of Line monitoring Resistor can be connected across the 24V+ and 0 terminals. Resistor values for the End of Line will be determined by the customer with a minimum value of 1.2kΩ

10.0 Maintenance

Little or no maintenance is required during the normal working life of the product. The Ex-Tech Signalling Exd enclosures are resistant to most acids, alkalis and chemicals and have been designed to withstand severe weather conditions. However it is suggested that to avoid the possibility of a potential electrostatic charge build up, the exterior of the product is periodically wiped down with a clean damp cloth. At this point a visual inspection is recommended to ensure that the product is in good working order and no damage has been sustained during its normal operation.

SAFETY WARNING

In the case of Anti Static and UV Resistant GRP, the painting of the enclosure surface has been processed specially. To maintain the product to be Anti Static, extra normal painting is not allowed. If any failure occurs but not caused by human factor, the product can be returned to Ex-Tech Signalling for free repair or replacement during the warranty.

11.0 Conditions for Safe Usage

[fi This apparatus is suitable only to be used in ambient temperature stated.

Type	Ambient Temp
BC150	-40°C to +70°C

[fi Do not paint or change the surface finish of the unit. The coating applied by the manufacturer is Anti-Static & UV Stable.

Specific Condition for Use

Repairs of the flameproof joints must be made in compliance with the structural specifications provided by the manufacturer. Repairs must not be made on the basis of values specified in tables 1 and 2 of EN/IEC 60079 -1.

Please contact Ex-Tech Signalling for further details.



INSTALLATION & TECHNICAL INFORMATION

PLEASE READ TO INSTALLATION



Type :			
CE 0470	II 2 GD	ATEX 13 NEMKO 1361X	
Ex d IIC T4 Gb	IP 66	IECEx, NEM 13.0030X	
Ex tb IIIC T135°C		CNEEx 10.2112X	
T. amb: -40°C < Ta < +70°C		P	25 Watt max
		U	<input type="checkbox"/> VDC <input type="checkbox"/> AC50/60Hz
		Serial N° :	
WARNING - DO NOT OPEN WHEN AN EXPLOSIVE ATMOSPHERE IS PRESENT			
 Ex-tech Signalling SAS			
Ex-tech Signalling SAS, Champniers, France - www.ex-tech.no			

Alternative T class:

- 1:
 - Ex d IIC T5 Gb
 - Ex tb IIIC T100°C
 - T. amb: -40°C < Ta < +60°C
- 2:
 - Ex d IIC T6 Gb
 - Ex tb IIIC T85°C
 - T. amb: -40°C < Ta < +55°C

BC150 Series - (Explosion Proof Beacon)

Glass Reinforced Polyester

VISUAL SIGNALLING DEVICES

APPROVALS AND
CONFORMITIES



1.0 Introduction

The BC150 range is certified for use and installation in Zone 1 and Zone 2 with gas groups IIA, IIB, IIC, also Zones 21 and 22 for Dust. The unit carries a temperature classification of T4~T6. It especially applies to Oil & Gas, Offshore Platform, Chemical, Petrochemical, Refinery and Marine Industries etc. Enclosure material is UV and corrosion resistance GRP (Glass Reinforced Polyester). Ex-Tech Signalling sas also recommends anti static GRP material for your consideration. Different flash or rotary rate can be adjusted from unique design. Three working statuses; flash type, rotary type and steady type are available (LED). There are two types of beacon (Xenon type and LED type) available for the customer.

2.0 Explosion Proof Labelling

All products have a rating label with the following important information: Product order no: eg BC150RX05DCNNNARDN

(Refer to the datasheet for product order selection)

Input voltage: 12-48V Dc or 100-240V Ac (50/60 Hz), ≤25W

Code: Ex d IIC T4~ T6 Gb, Ex tb IIIC T135°C~T85°C IP66

Nemko ATEX Certificate No: Nemko 13 ATEX 1561X

ATEX Mark:



IECEX Certificate: IECEX-NEM 13.0030X

Gas Group and Category: II 2GD

CE Mark: Mark No: 0470

Warning: **DO NOT OPEN WHEN AN EXPLOSIVE GAS ATMOSPHERE IS PRESENT**

Finished product serial no ie. BC150-110140001

BC150-GRP Beacon & Light, FRANCE-110, YEAR-14, Product Serial Number-0001

Table 2 - Xenon Beacon Frequency and Status Selection

All values in () are the numbers of flashes per time

DIP Switch		S1=OFF S2=OFF	S1=ON S2=OFF	S1=OFF S2=ON	S1=ON S2=ON
1st DIP	2nd DIP	Alarm Stage 1	Alarm Stage 2	Alarm Stage 3	Alarm Stage 4
0	0	OFF	60 times/min (1)	90 times/min (1)	120 times/min (1)
1	0	OFF	60 times/min (2)	60 times/min (3)	60 times/min (4)
0	1	OFF	60 times/min (3)	60 times/min (4)	60 times/min (5)
1	1	OFF	60 times/min (4)	60 times/min (5)	60 times/min (6)

8.0 Cable Gland

Only cable glands approved for Exd applications can be used with Ex-Tech Signalling Explosion Proof Products, these must be suitable for the type of cable being used and also meet the requirements of the Exd flameproof installation standard EN 60079-14.

SAFETY WARNING

If units are used at high ambient temperatures, ie over +40°C then the cable entry temperature may exceed +70°C and therefore suitable heat resisting cable glands must be used, with a rated service temperature of at least 95°C.

If a high IP (Ingress Protection) rating is required, a suitable sealing washer must be fitted under the cable gland. Any unused cable entry holes must be closed with an Exd flameproof blanking plug, which must be suitably approved for the installation requirements.

7.0 Alarm Status, Flash Pattern & Frequency Adjustment (Refer tables 1 & 2)

Flash Pattern/Frequency are set using the **DIP Switches-SW1** (Picture 2) located on the pcb in the top cover of the flameproof enclosure.

LED Beacon: 3 pole

Xenon Beacon: 2 pole

Binary code used in the tables: 0 = Off and 1 = On/(High)

Alarm Status: set via remote switching. **Factory Pre-set for Stage 2 Alarm**

Picture 1 - BASE PCB

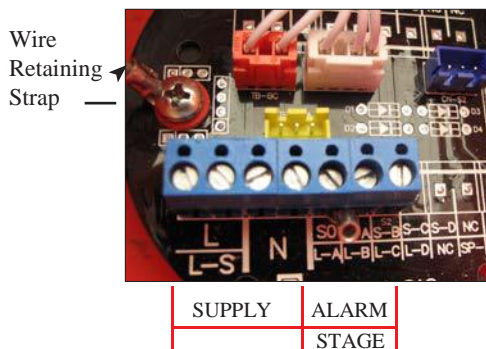

Picture 2 - TYPICAL COVER PCB

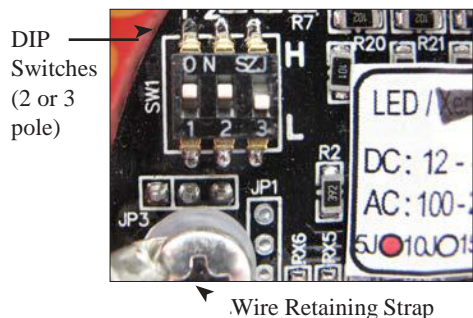

Table 1 - LED Beacon Frequency and Status Selection Values in () rate when 3rd DIP (1) On

DIP Switch			S1/S2	S1=OFF S2=OFF	S1=ON S2=OFF	S1=OFF S2=ON	S1=ON S2=ON
1st DIP	2nd DIP	3rd DIP	Alarm Stage 1	Alarm Stage 2	Alarm Stage 3	Alarm Stage 4	
0	0	0(1)	OFF	Flash 60 (75) times/min	Flash 75 (90) times/min	Steady light	
1	0	0(1)	OFF	Rotary 60 (75) times/min	Rotary 75 (90) times/min	Steady light	
0	1	0(1)	OFF	Triple Flash 60 (75) times/min	Triple Flash 75 (90) times/min	Triple Flash 100 (120) times/min	
1	1	0(1)	OFF	Flash & Rotary 60 (75) times/min	Flash & Rotary 75 (90) times/min	Flash & Rotary 100 (120) times/min	

3.0 Type Approval Standard

The Ex-Tech Signalling product range all have an EC Type Examination Certificate issued by Nemko and have been approved to the following standards:

EN 60079-0:2012 (IEC 60079-0:2011)
 EN-60079-1:2007 (IEC 60079-1:2007)
 EN 60079-31:2009 (IEC 60079-31:2008)

4.0 Zones, Gas Group, Category and Temperature Classification

The BC150 series products have been certified Ex d IIC T4~T6.

This means that the units can be installed in locations with the following conditions:

Area Classification:

Zone 1: Explosive gas air mixture likely to occur in normal operation.

Zone 2: Explosive gas air mixture not likely to occur, and if it does, it will only exist for a short time.

Gas Groupings:

IIA Propane Group, IIB Ethylene Group, IIC Hydrogen and Acetylene

Zone 21: Explosive dust air mixture likely to occur in normal operation.

Zone 22: Explosive dust air mixture not likely to occur, and if it does, it will only exist for a short time.

Equipment Category: 2GD

Temperature Range: $-40^{\circ}\text{C} < T_a < 70^{\circ}\text{C}$

5.0 Installation

General Requirement

Selection, Installation, Maintenance and repair of electrical apparatus for use in potentially explosive atmosphere should be done in accordance with IEC/ EN 6079-14/-17/ -19.

Product installation must be carried out in accordance with any local codes that may apply and should only be carried out by a competent electrical engineer.

Location

The location of the unit should be chosen with due regard to the area over which the beacon warning signal must be visible/audible. The unit should only be fixed to services that can support the weight of the unit.

Mounting

The unit should be mounted on a vertical surface using four fixing holes in the base. The fixing holes are designed to fit M8 Allen Screw only. Use of stainless steel fastener is recommended by Ex-Tech Signalling. The beacon can be operated in any attitude. If you need a mounting plate, please contact Ex-Tech Signalling to ask for the mounting plate installation drawing (see diagram 1).

Diagram 1

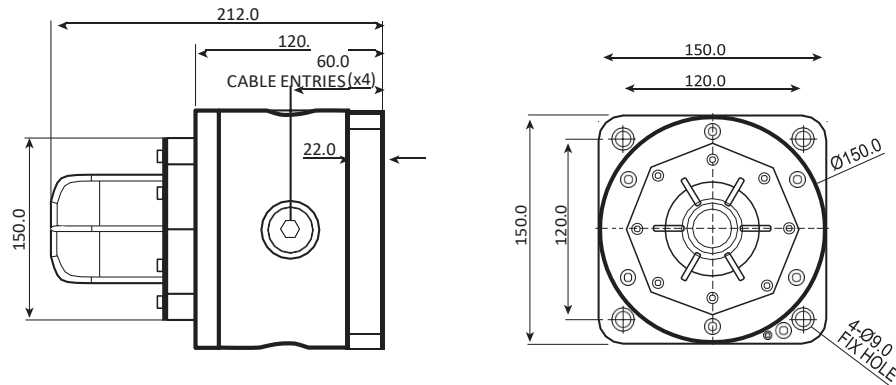

6.0 Wiring

General Requirement

Ex-Tech Signalling recommends that all cables and cores should be fully identified (suggest using cable from 2.0 to 2.5 mm²). Ensure that all nuts, bolts and screws are secured. Ensure that only the right and certified cable glands are used and earthed correctly. Ensure that only the right and certified stopping plugs are used to blank off unused gland entry points. In order to maintain the IP rating of the product, we recommend SS316 for this application.

Cable Connection: The Supply and Alarm Status cable is connected to the terminals located in the flameproof enclosure base (Picture 1 and separate wiring drawing). For **AC Supply** – to terminals marked **L** & **N**. Terminals provide loop in loop out facility.

For **DC Supply** - connect “+” to **L** and “0” to **N**.

Alarm Status - to terminals marked ‘**S0**’ (common) & ‘**S1**’, ‘**S2**’ (Refer clause 7.0 - see tables).

Do not connect Ac or Dc to terminals **S0, S1, S2**

Remove of Top Cover (Beacon Component)

CAUTION: Before removing the cover, ensure the power to beacon is isolated.

Unscrew the six (6) M5 retained Hexagon socket head screws to open the cover. Twist the cover gently clockwise and anti-clockwise, whilst pulling away from the base, until it comes off.

Note; it recommended to open one bling plug to avoid internal vacuum in the unit.

This will release the cover from the base and allow the cover to hang on the retaining wire strap. Before replacing the cover, check that the flameproof joints are clean and not damaged, the gasket is still retained in its groove. As lubrication / grease for the flameproof joint, a thin film of Acid free Vaseline (soap-thickened mineral oils) or mineral oil can be used, excessive lubrication/ grease shall be removed before assembling. Reinstall the cover in similar way, but operate in reverse manner as above.

Recommended Bolt Torque for M5 lid screws are 4.5Nm.

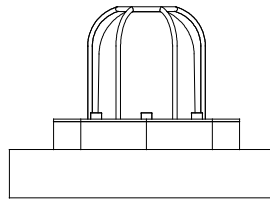

BEACON

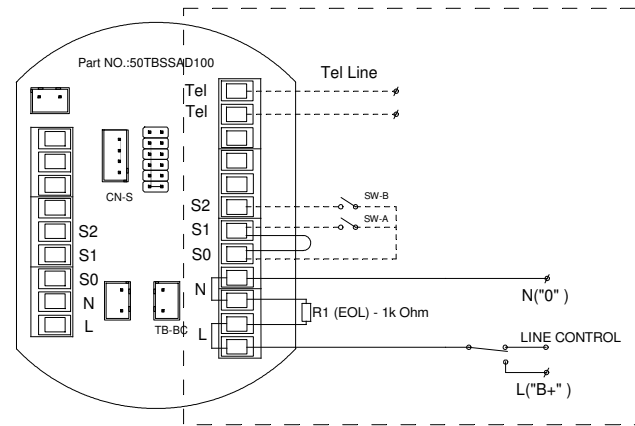
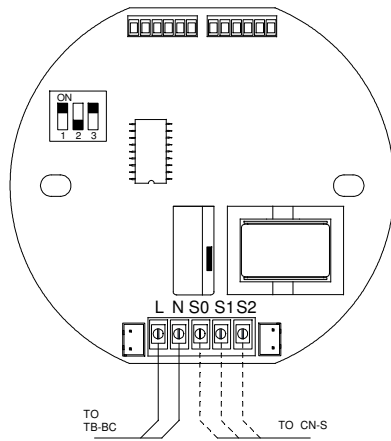

Wiring For Customer

00 - 08/11/2016	Création		
Revision - date	Reason		
Material		 Size : A3	
Treatment			
Specifications			
Drawing part	Scale : 1 : 1	Project / N° PO	Dossier
WIRING DIAGRAM BC100_125_150 - EOL	Drawn by : P. TRAUMAT	-	-
	Date : 08/11/2016	N° Drawing BC100_125_150	Index Folio 01 1/1

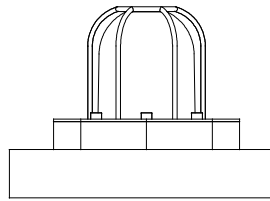

BEACON

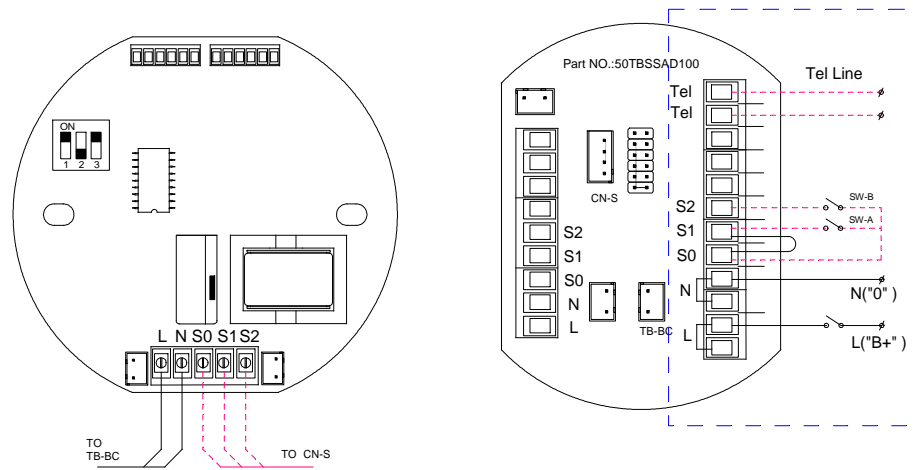

Wiring For Customer

Wiring Method

Connect power supply line to terminals "L" and "N". If power supply is DC. "L" presents "+", "N" presents "0".

supply control method:

Turn on the SW-BC to start BEACON (Short S0 to S1);

No power supply control method:

Turn on the SW-A to start BEACON.

If you want to add resistor, please connect the resistor to the "L" & "N".

Telephone Initiated PCB Function

1. Connect the telephone line to the "Tel" terminals.
2. The unit will flash when telephone rings.
3. The unit will stop flashing when the telephone handset is picked up.

Please refer to our product technical manual for more details.

Cable Selection

Please select suitable size cable according to the distance between control room & the terminals and the quantity of equipments used.

Normal size for AC power supply cable L & N is 1.5mm². Normal size for DC power supply cable L & N is 2.5mm².

Please select the quantity of control cables (0 to 3) according to the actual requirement. Normal size for control cable is 1mm².

00 - 21/10/2015	Creation				
Revision - date	Reason				
Material				Size : A3	
Treatment				Ex-tech Signalling	
Specifications				Project / N° PO	
Drawing part		Scale: 1 : 1	-		Dossier
WIRING DIAGRAM BC100_125_150		Drawn by: P. TRAUMAT	-		
		Date: 01/10/2015	N° Drawing BC100_125_150	Index 01	Folio 1/1